



Project 006 Rotorcraft Noise Abatement Operating Conditions Modeling

The Pennsylvania State University, Continuum Dynamics, Inc., Bell Helicopter Textron, Inc., Sikorsky Aircraft Corporation

Project Lead Investigator

Kenneth S. Brentner
Professor of Aerospace Engineering]
Department of Aerospace Engineering
The Pennsylvania State University
233 Hammond Building, University Park, PA
(814) 865-6433
ksbrentner@psu.edu

University Participants

The Pennsylvania State University

- P.I.: Kenneth S. Brentner, Professor of Aerospace Engineering
- FAA Award Number: 13-C_AJFE-PSU-006, Amendment No. 6
- Period of Performance: August 18, 2014 to January 31, 2016
- Task(s):
 1. Prediction system development
 2. Noise prediction system validation
 3. Noise predictions and noise mapping
 4. Flight test plan development
 5. Determination and development of data path to AEDT
 6. Selection and modeling of notional advanced technology rotorcraft
 7. Noise predictions and data preparation for AEDT

Project Funding Level

FAA: \$250,326; In-Kind Match: (Continuum Dynamics, Inc: \$112,500 to PSU and \$75,000 to FAA; Bell Helicopter Textron, Inc.: \$37,500; Sikorsky Aircraft Corporation: \$37,500)

Investigation Team

Kenneth S. Brentner, PI, The Pennsylvania State University; acoustics predictions lead on all tasks.

Joseph F. Horn, Co-PI, The Pennsylvania State University; flight simulation lead supporting all tasks

Daniel A Wachspress, Co-PI, Continuum Dynamics, Inc.; responsible for rotor loads and wake integration and CHARM coupling, primarily involved in tasks 1-3, and 6,7.

Yaowei Li, Graduate Research Assistant, The Pennsylvania State University; primary responsibility for coupling acoustic code into noise prediction system and acoustic predictions in tasks 1-3.

Willca Villafana, Graduate Research Assistant, The Pennsylvania State University; primary responsibility for model setup and acoustic predictions in tasks 3, 5-7.

Adam Thorsen, Graduate Research Assistant, The Pennsylvania State University; assisted in development of flight simulation code in task 1.

Umberto Saetti, Graduate Research Assistant, The Pennsylvania State University; assisted in flight simulation coupling and performing coupled simulations in tasks 2, 3, and 7.

Benjamin A Goldman, Industrial Partner, Bell Helicopter Textron, Inc.; support Bell 430 model setup and validation of the noise prediction system in task 1 and 2, provide feedback on all aspects of project, especially tasks 1-4.

Eric Jacobs, Industrial Partner, Sikorsky Aircraft Corporation; primary responsibility for flight test plan development in task 4, provide feedback on all aspects of project, especially tasks 3 and 4.

Project Overview

Rotorcraft noise consists of several components including rotor noise, engine noise, gearbox and transmission noise, etc. Rotor noise is typically the dominant component of rotorcraft noise that is heard by the community upon takeoff, landing, and along the flight path of the helicopter. Rotor noise consists of several different noise sources including thickness noise and loading noise (together typically referred to as rotational noise), blade-vortex-interaction (BVI) noise, high-speed-impulsive (HSI) noise, and broadband noise – with each noise source having its own unique directivity pattern around the helicopter. Furthermore, any aerodynamic interaction between rotors, interaction of the airframe wake and a rotor, or unsteady, time-dependent loading generated during maneuvers typically results in significant increases in loading noise. The combination of all the potential rotor noise sources makes prediction of rotorcraft noise quite complex, even though not all of the noise sources are present at any given time in the flight (e.g., BVI noise usually occurs during descent and HSI noise only occurs in high-speed forward flight).

The rotorcraft industry, universities, and government research labs have actively engaged in research activities since the late 1960's to understand rotorcraft noise generation mechanisms and mitigation techniques. Both first principles and semi-empirical prediction tools have been developed as a result of this research. This project will leverage that research and use tools developed by the research team to develop noise abatement flight procedures and a flight test plan to evaluate the effectiveness to those procedures. The noise prediction system will also be used to demonstrate its utility in predicting the noise from advance rotorcraft features and concepts.

Objectives

There are two main objectives for this project, described as follows:

- (1) The first objective of this activity is to develop rotorcraft noise abatement procedures through computational and analytical modeling, and develop a comprehensive flight test plan to validate the effectiveness of resulting noise abatement flight procedures. This objective is addressed through the implementation of tasks 1-4 described below.
- (2) The second objective is to use the computational and analytical modeling tools to demonstrate the ability to provide vehicle noise data for notional vehicles with advanced technology in a manner than can be used in the FAA Aviation Environmental Design Tool (AEDT). This objective is addressed in tasks 5-7 described below.

The approach to developing rotorcraft noise abatement procedures requires the ability to compute the vehicle noise from the relevant noise sources in level flight, hover, takeoff, and approach. Emphasis will be given to the level flight conditions for conventional helicopters, but the tools coupled together will be able to predict the noise from tandem, tiltrotor, and compound rotorcraft as well. In normal civil operations only rotor noise is expected to be a significant source of community noise. For this reason, engine noise, and other noise sources that are important in the cabin are not planned for consideration. Furthermore, high-speed-impulsive (HSI) noise during high-speed forward flight should be avoided in civil operations; therefore, HSI noise will not be considered.

The approach planned to demonstrate computational and analytical modeling tools on advanced rotorcraft designs will leverage the work done for Objective 1 (tasks 1-3, described below). For this reason the work on the second objective did not begin until approximately 6 months into the effort.

Task 1. Prediction System Development

The Pennsylvania State University

Objective(s)

The object of this task is to couple together a flight simulator, rotor aerodynamics and wake computation, and a noise prediction code to form a noise prediction system that will be capable of predicting helicopter noise in various flight operations.

Research Approach

For this effort the PSU-WOPWOP code will be used for noise prediction, and will be coupled with a MatLab flight simulator and CHARM (Comprehensive Hierarchical Aeromechanics Rotorcraft Model) to form a rotorcraft noise prediction system.

Both CHARM and PSU-WOPWOP have previously been coupled (individually) to the flight simulation code GENHEL-PSU (which models helicopters similar to the Sikorsky UH-60), the three codes have not been coupled together into a single noise prediction system. The first major task of this project is to update and enhance the coupling between the three codes. A newly developed flight simulation code will be used to compute the time-dependent flight state of the aircraft and initial blade loading and blade motion estimates. These results will be passed to the CHARM code (module) to predict the rotor wakes and resulting time-dependent blade loads. The loading output of these coupled codes will be input to PSU-WOPWOP to compute the noise during the helicopter flight operation.

The coupling is time accurate because that is the normal operation mode of each of the codes. The initial coupling will include multiple rotors (main rotor/tail rotor) and noise computations for noise certification flight conditions and microphone locations will be demonstrated. Two forms of coupling are used; the first (shown in Fig. 1.1) is a coupling in which the CHARM airloads computations are decoupled from the flight simulator. In this approach, the airloads and trim determined by the flight simulator may be different from those computed in CHARM and used in the noise prediction. To address this potential problem, a fully coupled approach was also developed (shown in Fig. 1.2).

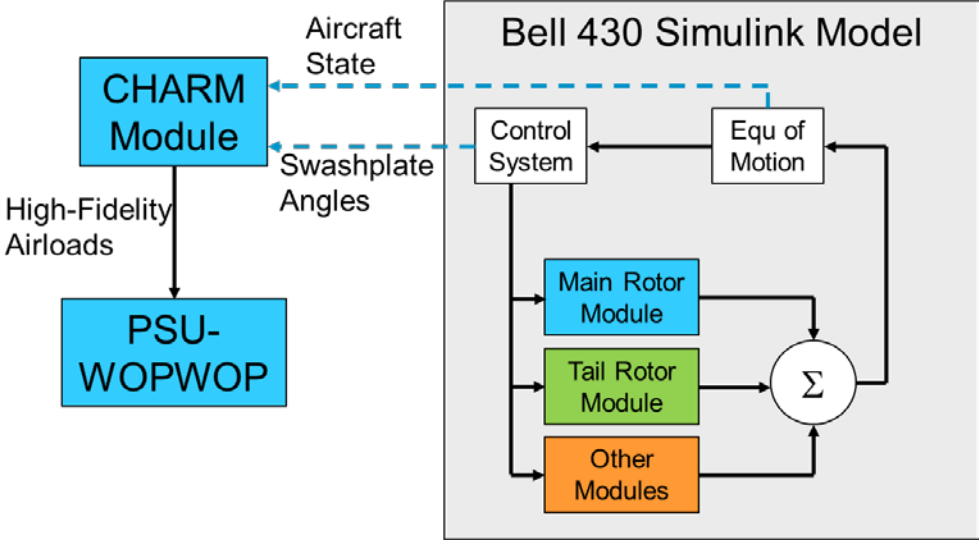

Figure 1.1 Integration Method 1 – CHARM de-coupled from flight simulator.

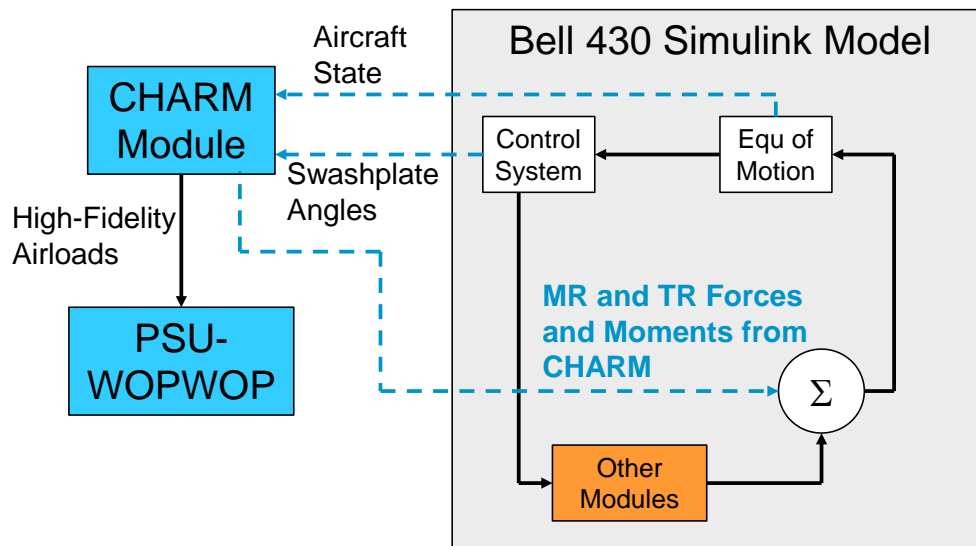

Figure 1.2. Integration Method 2 - CHARM fully coupled with flight simulator.

The noise prediction system is anticipated to be sufficiently fast to predict the noise during an entire operation (several seconds at least) at a large number of observer locations so that noise contours on the ground can be predicted. The time accurate nature of the system will enable sweeps of control parameters to be evaluated to eliminate blade-vortex interaction (BVI) or other high noise conditions. This tool will enable the development and analysis of noise abatement flight procedures through relatively rapid computations.

The noise prediction system is envisioned to only predict the rotor noise, but should be able to predict noise from helicopters, compound rotorcraft, and tiltrotors (i.e., the number and placement of rotors is not a problem). The system will be able to predict rotor noise in all normal operating flight conditions, ranging from hover (IGE or OGE), takeoff, level flight, approach, and maneuvering flight. Engine and related noise sources are not planned in this project.

Milestone(s)

The coupled noise prediction system was largely complete after the first 3 months, but as problems are encountered (i.e., software bugs), the system is corrected.

Major Accomplishments

The primary accomplishment of this task is the coupling of the three components (flight simulator, high fidelity rotor airloads and airwake (CHARM), and noise prediction (PSU-WOPWOP)) is new.

Another accomplishment was the development of the MatLab based flight simulation code (called HeloSim). This flight simulator is relatively simple because it does not need detailed rotor aerodynamics or wake models - the CHARM rotor module coupling provides higher fidelity loading to the flight simulator.

Publications

None

Outreach Efforts

None

Awards

None

Student Involvement

Adam Thorsen, Ph.D. student at PSU – provided limited support setting up MatLab based flight simulation tool.

Yaowei Li, M.S. student at PSU – primarily responsible for setting up and making acoustic predictions and analysis of acoustic data. He was also involved in developing the coupling between codes. Graduated August 2015. Plans after graduation unrelated to the project.

Plans for Next Period

This task of Project 6 is essentially complete. Any software “bugs” found during the noise predictions in the other tasks will be corrected as required.

Task 2. Noise Prediction System Validation

The Pennsylvania State University

Objective(s)

This task will validate the noise prediction system to demonstrate that is sufficiently accurate to be used for the development and analysis of rotorcraft noise abatement flight procedures.

Research Approach

The noise prediction system will be validated through prediction of various flight conditions and comparison with recently acquired flight test data. NASA, Bell Helicopter, and the U.S. Army recently performed a maneuver acoustics flight test with the Bell 430 helicopter (Ref. 2.1). The data from this test provides an excellent opportunity to test the maneuver noise prediction system and demonstrate its accuracy, strengths and weaknesses. Data from this test is publicly available and as a partner in this effort, Bell will be able to provide insight into the details of this flight test, which is very valuable in the validation effort. The primary goal of this validation is to characterize the accuracy of the system (with low to medium fidelity level), which will provide sufficiently short noise prediction times needed in noise abatement procedure development. It may also show “gaps” in the system that need to be addressed.

The noise prediction system predictions were compared to measurements from a cooperative flight test conducted by NASA, Bell Helicopter and the U.S. Army to characterize the steady state acoustics and measure the maneuver noise of a

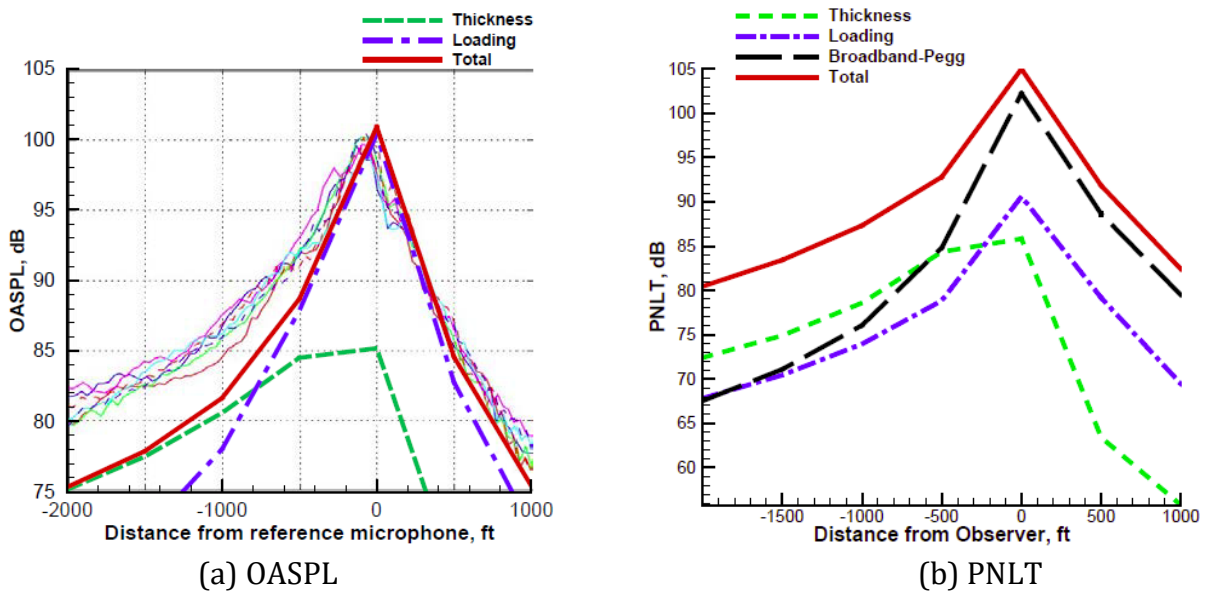

Figure 2.1 OASPL and PNLT levels for 80 kts level flight “housekeeping” run.



Bell Helicopter 430 aircraft (Refs. 2.2, 2.3). For the first validation comparison, a level flight “housekeeping condition” is modeled in which the aircraft was flown several times at nominally the same flight speed (80 kts) over the reference microphone. For this case the overall sound pressure level (OASPL), plotted as a function of distance along the flight path, has been compared to the noise prediction system results (shown in Fig. 2.1). In Fig. 2.1 the reference microphone is at $x = 0$ m and the distance on the x-axes indicates the position of the aircraft relative to the reference point. Figure 2.1(a) shows the OASPL levels as a function of where the helicopter is during the level flyover. The noise is underpredicted when the helicopter is approaching the microphone (uprange), but the OASPL levels agree reasonably well when the aircraft is overhead or downrange. This underprediction of in-plane noise (the helicopter is uprange) is not unusual, but should be considered in future predictions. In Fig. 2.1(b) it is clear that each component of noise (thickness, loading, and broadband) is important when the frequency of the noise is considered – as it is in tone corrected perceived noise level (PNLT) measurements.

In Fig. 2.2 the acoustic pressure time history prediction during a mild BVI noise case is compared to measure data for the same condition. The primary character and levels are predicted reasonably well, but the BVI noise spikes are underpredicted. It is likely that a small change in predicted helicopter trim would adjust the BVI spikes substantially.

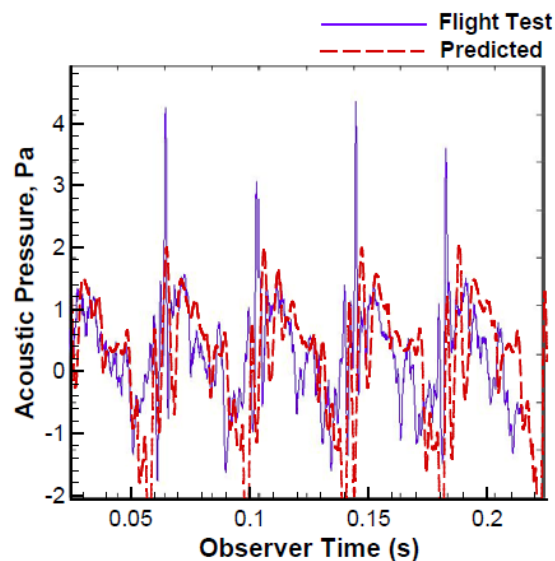

Figure 2.2 Acoustic pressure time history for 100 kts forward speed with 3 degree descent angle.

Milestone(s)

Completed validation of noise prediction system for level flight and descent (blade-vortex interaction) cases by comparison with flight test data for the Bell 430 helicopter.

Major Accomplishments

The validation of the noise prediction system in both level flight and a blade-vortex-interaction flight conditions is a significant achievement for the project. The agreement between the predicted and measured results is quite reasonable for fidelity of these tools and it demonstrates that the tools are able to predict the significant physical noise sources that must be modified to achieve noise abatement. This validation enables the noise prediction system to be used for the other tasks in the project with a degree of confidence.

Publications

Li, Y.; Brentner, K.S.; Wachspress, D.A.; Horn, J.F.; Saetti, U.; and Sharma, K., “Tools for Development and Analysis of Rotorcraft Noise Abatement,” proceedings of AHS “Sustainability 2015” conference, Montreal, Quebec, Canada, Sept 22-24, 2015, 10 pages.

Outreach Efforts

The validation effort summarized here was described to Juliet Page and David Senzig, both of VOLPE.

The validation effort was also highlighted in the conference presentation: Li, Y.; Brentner, K.S.; Wachspres, D.A.; Horn, J.F.; Saetti, U.; and Sharma, K., "Tools for Development and Analysis of Rotorcraft Noise Abatement," presented at AHS "Sustainability 2015," Montreal, Sept 22-24, 2015, (presented by K.S. Brentner).

Awards

None

Student Involvement

Yaowei Li, M.S. student at PSU – primarily responsible for setting up and making acoustic predictions and analysis of acoustic data. Graduated August 2015. Plans after graduation unrelated to the project.

Umberto Saetti, M.S. student at PSU – primarily responsible for flight simulation calculations and development and debugging of the coupling between the flight simulation code and the CHARM rotor module. Expected graduation August 2016.

Plans for Next Period

This validation effort is essentially complete. No further work is currently planned for validation.

References

- [2.1] Watts, M.E., Greenwood, E., Smith, C.D., Snider, R., and Conner, D. A., "Maneuver Acoustic Flight Test of the Bell 430 Helicopter Data Report," NASA/TM-2014-218266, May 2014.
- [2.2] Watts, M. E., Greenwood, E., Smith, C. D., Snider, R., and Conner, D. A., "Maneuver Acoustic Flight Test of the Bell 430 Helicopter Data Report," NASA/TM-2014-218266, May 2014.
- [2.3] Snider, R., Samuels, T.O., Goldman, B., and Brentner K. S., "Full-Scale Rotorcraft Broadband Noise Prediction and its Relevance to Civil Noise Certification Criteria," Proceedings of American Helicopter Society 69th Annual Forum, Phoenix, Arizona, May 21–23, 2013.

Task 3. Noise Predictions and Noise Mapping

The Pennsylvania State University

Objective(s)

This object of this task is to examine several flight conditions and consider operational changes and determine the impact on the noise levels. The goal of this task is to demonstrate how flight operations can reduce the noise.

Research Approach

In order to demonstrate the impact of noise abatement flight procedures, several simple parametric studies were performed. According to Helicopter Association International's "Fly Neighborly Guide", published report in 2007 (Ref. 3.1), the simplest way to reduce the rotorcraft noise during overflight is to increase the altitude and fly slower. To examine these common sense recommendations, the noise prediction system was used to predict the noise for various operating procedures. These predictions serve two purposes: 1) to develop further confidence that the noise prediction system captures the important noise characteristic of helicopters in various flight conditions; and 2) to provide detailed information that explain the mechanisms and directivity of noise changes (hopefully reductions) obtained through noise abatement flight procedures. Based on this guidance, the noise prediction system was used to predict the noise of the Bell 430 aircraft.

Impact of Altitude

The first case considered was level flyover with the Bell 430 helicopter flown with a velocity of 100 kts at different altitudes ranging from 150 m to 350 m in 50 m increments. This range of altitudes is arbitrary, but sufficient to demonstrate the powerful impact that distance makes in reducing noise. The aircraft weight and atmospheric conditions (standard sea level density and temperature) are held constant for each altitude. In Fig. 3.1 the PNLT is shown for locations directly below the flight path of the aircraft. In this figure it is evident that distance plays an important role in the noise level – as was expected. The peak PNLT level is about 8 dB lower for the 350 m case than for the 150 m altitude.

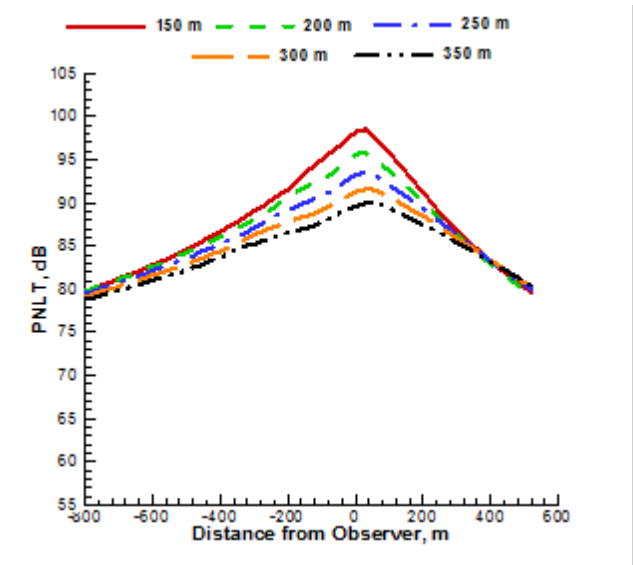
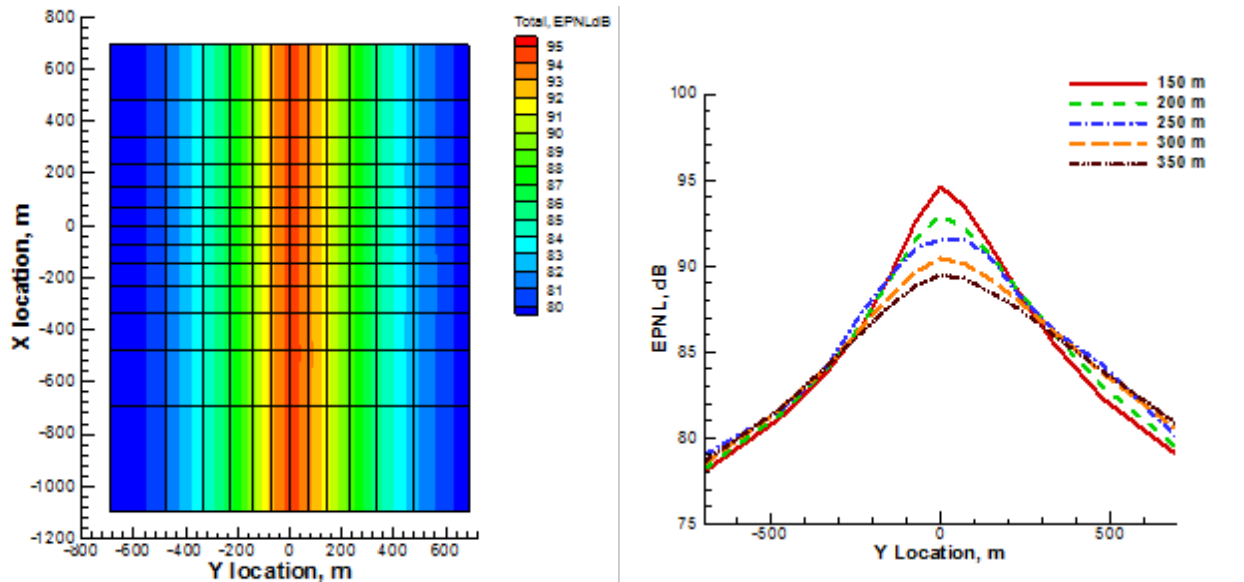

Figure 3.1 PNLT predictions for the Bell 430 helicopter with the aircraft at different flight altitudes.

While the behavior directly below the helicopter is what is expected – increased altitude decreases the noise level – this is not necessarily the case for observer locations to either side of the aircraft. Furthermore, the flight time over the observer is not included when considering the PNLT levels alone. To address these issues, the Effective Perceived Noise Levels (which are based on PNLT) were computed for an area below the aircraft (shown in Fig. 3.2). In Fig. 3.2(a) the EPNL levels are shown for a single altitude (150m) for approximately 1800m range and 700 m to either side of the flight path. The EPNL levels are highest directly under the aircraft, as would be expected. Notice that the EPNL levels do not vary with the x location because the helicopter is in level flight; thus a more quantitative examination of the results can be done by comparing the levels at the $x = 0$ position for different lateral distances from the centerline (shown in Fig. 3.2(b)). Again in this figure, it is clear that as the altitude of the helicopter increases the noise levels decrease along the centerline. But at lateral distances greater than 300m (in this case), the noise levels are relatively unaffected and even increase slightly on the right side of the aircraft (advancing rotor side). Hence, even for a very straight forward approach to noise abatement, the results will not be the same at all observer positions.



(a) EPNL contours, $V_H = 100$ kts, altitude = 150m

(b) EPNL at $x = 0$ plane, $-700 < y < 700$ m for various altitudes

Figure 3.2 Effective Perceived Noise Levels for Bell 430 helicopter flying at 100 kts at altitudes from 150m to 350 m.

Impact of Flight Speed

A similar comparison of EPNL levels was performed for the Bell 430 operating at forward speeds ranging from 60 kts to 140 kts in level flight at 150m (shown in Fig. 3.3). It is generally understood that flying slower will reduce the noise levels. The physics of the source noise mechanisms (in-plane noise in particular) indeed exhibit this behavior. But when the EPNL is considered, which takes into account the duration of the exposure as well as the level, the levels of EPNL do not change significantly below the helicopter even though the expected trend is seen away from the centerline (see Fig. 3.3). The reason for this is that while the noise level is lower for low speed (e.g., 60 kts), the exposure time is longer. So along the helicopter flight path the EPNL levels are essentially the same for the 60 kts and 140 kts cases.

Impact of Flight Path Angle

The Sound Exposure Level (SEL) contours were also computed for different descent and climb angle (from 6 deg. descent to 6 deg. climb). When the helicopter is not in level flight, the distance to the ground will be constantly changing and it has already been shown that increasing distance is an effective noise abatement strategy. Therefore, in these comparisons, the distance from the measurement plane is the same for $x = 0$ and either farther or closer to the plane otherwise. The comparison for 6 deg. and 3 deg. descent angle is shown in Fig. 3.4 (along with the level flight case as a reference). The SEL levels are significantly higher for the 6 deg. descent. For the uprange cases ($x < 0$) the impact of distance should be to reduce the level, but they are higher than the 3 deg. and level flight cases. Also it is clear at $x = 0$ that the levels are higher, yet the distance is the same here. Upon closer examination, the 6 deg. descent case has significantly more BVI than the 3 deg. descent case, and the level flight case does not have any BVI noise. Thus it is clear that BVI should be avoided to have the lowest noise (and annoyance) levels.

In Fig. 3.5, the SEL contours for 6 deg. and 3 deg. climb are shown (along with a level flight case for reference). In this case the change in SEL levels is primarily due to the distance the helicopter is above the measurement plane. This can be

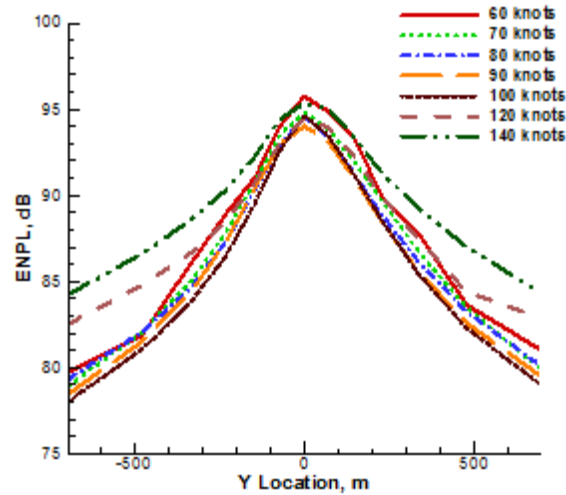

Figure 3.3 ENPL along $x = 0$ plane, $-700 \leq y \leq 700$ m for forward speeds ranging from 60 kts to 140 kts.

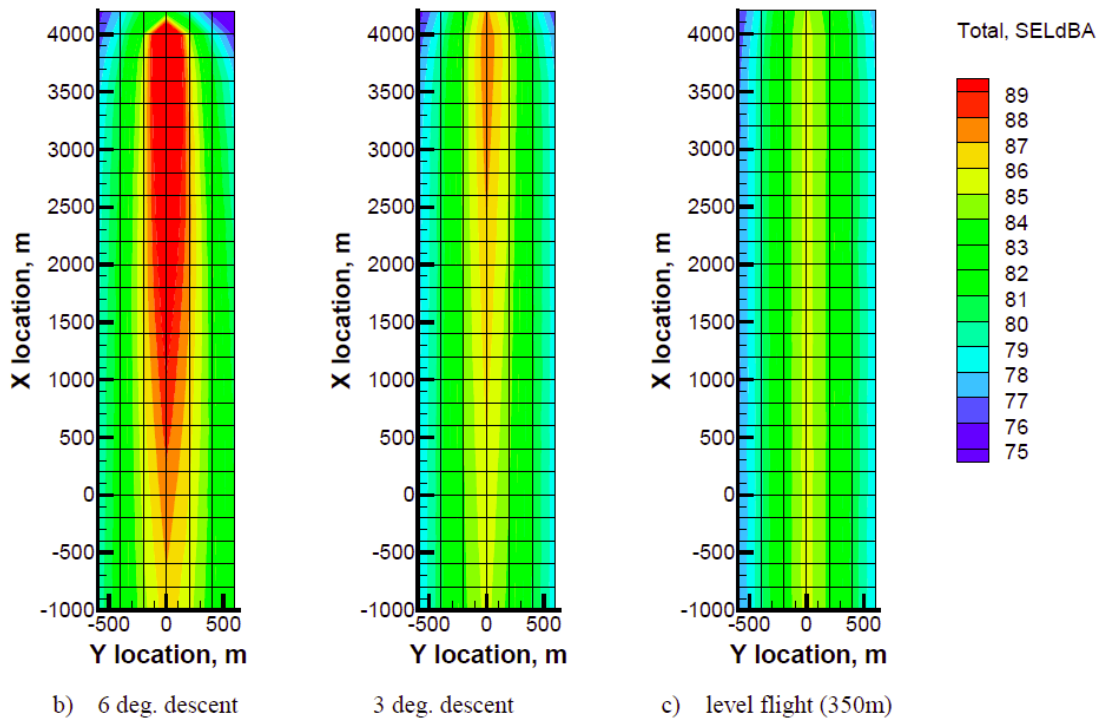

Figure 3.4 SEL contour plots for various descent angles.

seen by comparing the values at $x = 0$, which are essentially the same. So unlike the descent case where BVI noise was eliminated by changing the descent angle, there is no change in the physics in the climb case. Nevertheless, rapid climb is an effective means of increasing the distance and thereby reducing the noise.

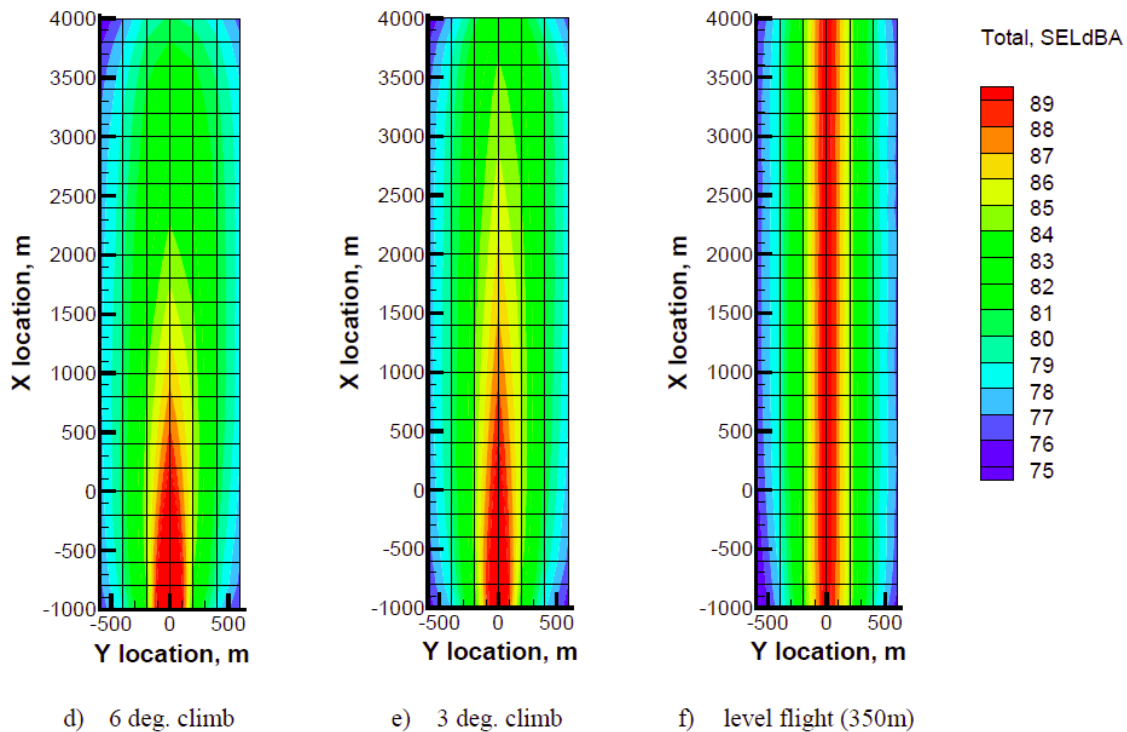

Figure 3.5 SEL contour plots for various climb angles.

Milestone(s)

Compute predicted noise for several operating scenarios. This milestone was met by the level flight, descent, and climb cases studied.

Major Accomplishments

This task has demonstrated the noise prediction system is able to show how different rotorcraft operations can reduce or increase the noise levels. Furthermore, the predictions have shown that even simple noise abatement strategies, like flying higher or flying slower, may provide noise reduction in some locations and yet result in increases in other locations. This task has demonstrated that to understand such complex changes it is important to have a physics-based noise prediction system so that a detailed investigation of the individual noise components and the noise directivity can be made.

Publications

Li, Y.; Brentner, K.S.; Wachspress, D.A.; Horn, J.F.; Saetti, U.; and Sharma, K., "Tools for Development and Analysis of Rotorcraft Noise Abatement," proceedings of AHS "Sustainability 2015" conference, Montreal, Quebec, Canada, Sept 22-24, 2015, 10 pages.

Outreach Efforts

The validation effort summarized here was described to Juliet Page and David Senzig, both of VOLPE.

The validation effort was also highlighted in the conference presentation: Li, Y.; Brentner, K.S.; Wachspress, D.A.; Horn, J.F.; Saetti, U.; and Sharma, K., "Tools for Development and Analysis of Rotorcraft Noise Abatement," presented at AHS "Sustainability 2015," Montreal, Sept 22-24, 2015, (presented by K.S. Brentner).

Awards

None

Student Involvement

Yaowei Li, M.S. student at PSU – primarily responsible for setting up and making acoustic predictions and analysis of acoustic data for Objective 1. He was also involved in developing the coupling between codes. Graduated August 2015. Plans after graduation unrelated to the project.

Umberto Saetti, M.S. student at PSU – primarily responsible for flight simulation calculations and development and debugging of the coupling between the flight simulation code and the CHARM rotor module. Expected graduation August 2016.

Plans for Next Period

This task is essentially complete. No additional work is planned, but if support is needed to finish the flight test plan development (task 4) then noise predictions could be made in support of that task.

References

[3.1] Fly Neighborly Guide, produced by the Helicopter Association International Fly Neighborly Committee, 2007. (<http://www.rotor.org/portals/1/operations/Fly2007.pdf> - accessed March 27, 2015)

Task 4. Flight Test Plan Development

The Pennsylvania State University

Objective(s)

This task will develop a draft flight test plan for evaluation of noise abatement procedures.

Research Approach

A draft test plan to test the effectiveness of various noise abatement procedures is being developed, based primarily upon the experience of our industrial partners Sikorsky Aircraft Corporation and Bell Helicopter Textron, Inc. Eric Jacobs at Sikorsky Aircraft Corporation is leading the development of this plan. The flight test plan will involve two phases of testing. Phase 1 will include noise characterization and model validation testing. This will provide the baseline to compare noise abatement procedures against and to determine if changes in the test plan are needed to take into account noise characteristics that may not be fully account for in the noise modeling. The Phase 2 plan will define the abatement procedures to be tested and the test conditions required to ensure the test is effective. The draft test plan will have several “to be determined” items because the target aircraft and test site are not currently known, but are critical elements of such a plan. These items will likely not be determined until a specific test is planned (or at least proposed).

Milestone(s)

The flight test plan development is currently in progress.

Major Accomplishments

An outline of the test plan and initial Phase 1 plan has been drafted. The Phase 2 test plan is currently under development.

Publications

None

Outreach Efforts

None

Awards

None

Student Involvement

None

Plans for Next Period

The flight test plan will be finished during the next few months of the project.

Task 5. Determination and Development of Data Path to AEDT

The Pennsylvania State University

Objective(s)

The object of this task is to develop the necessary noise prediction templates and post processing capabilities to generate noise with the rotorcraft noise prediction system developing in task 1 and generate the needed data, in the proper format, to be used in AEDT in lieu of manufacturer provided, or otherwise measured, data.

Research Approach

The first step is to determine the appropriate information that AEDT needs from the rotorcraft noise prediction system. This includes helicopter noise levels and directivity for various operating conditions and will likely need to be provided in some form of noise-power-distance (NPD) curves, spectral class data, etc. A different set of NPD data is required for each flight operational mode. The rotorcraft noise prediction system will have the advantage that for any given flight condition, the noise can be predicted in any direction (or on a sphere surrounding the vehicle). While such data is not currently used in AEDT, it can be used to determine if current and any advanced modeling in AEDT are capturing the nature of the helicopter noise sufficiently. Noise prediction templates will be developed to simplify the process of computing NPD and spectral class data. Ultimately the goal would be to set up the helicopter model in the rotorcraft noise prediction system, do some testing to make sure the setup is correct, and then submit a batch job and get out the data needed by AEDT.

Milestone(s)

Review input data requirements for AEDT and develop necessary post processing capabilities to provide any data or data format as needed. The work on this milestone is underway and nearly complete.

Major Accomplishments

Work on this task is currently underway and is nearly completion. All the information needed is currently computed by PSU-WOPWOP and the ongoing work is to set up the templates and post processing tools to compute and write out results in a format that can be used by AEDT.

Publications

None

Outreach Efforts

We have had several interactions with Juliet Page, VOLPE, to help us understand the noise inputs requirements of AEDT.

Awards

None

Student Involvement

Willca Villafana, M.S. student at PSU – primarily responsible for acoustic work in Objective 2, i.e., preparing the noise prediction system to output the necessary data for input to AEDT. Expected graduation August 2016.

Plans for Next Period

It is anticipated that this task will be completed during the next few months.

Task 6. Selection and Modeling of Notional Advanced Technology Rotorcraft

The Pennsylvania State University

Objective(s)

The objective of this task is to select a small number of advanced technology rotorcraft features to demonstrate how the noise prediction system can help assess the potential for new technology to impact rotorcraft noise abatement or how it may be assessed as part of the total air transportation system noise through modeling inputs for AEDT (before measured data would be available).

Research Approach

A limited number of notional rotorcraft with advanced technologies can be studied within the scope of this effort. Therefore, it is planned to select three new technologies that have a strong potential for noise reduction. These technologies will be integrated into notional rotorcraft, which in turn will be analyzed as representative cases. Ultimately the goal is to demonstrate that advanced technology rotorcraft could be studied within the context of AEDT and their noise impact/noise reduction could be assessed in the broader context provided by AEDT. Three technologies that would be good candidates are: a) active flap rotors (for BVI noise reduction); b) multi-speed/variable-speed rotors; and c) a compound rotorcraft (which might not reduce noise, but may potentially have a significant noise impact). All the rotorcraft configuration details will need to be developed and tested to ensure they are reasonable in this task.

Milestone(s)

Develop notional advanced rotorcraft configurations and build the necessary inputs for the rotor noise prediction system. This milestone is not schedule to be completed until the 15th month of the project.

Major Accomplishments

Work on this task is underway, but has only recently started.

Publications

None

Outreach Efforts

None

Awards

None

Student Involvement

Willca Villafana, M.S. student at PSU – primarily responsible for acoustic work in Objective 2, i.e., preparing the noise prediction system to output the necessary data for input to AEDT. Expected graduation August 2016.

Umberto Saetti, M.S. student at PSU – primarily responsible for flight simulation calculations and development and debugging of the coupling between the flight simulation code and the CHARM rotor module. Expected graduation August 2016.

Plans for Next Period

This task will be completed during the next year.

Task 7. Noise Predictions and Data Preparation for AEDT

The Pennsylvania State University

Objective(s)

The objective of this task is to demonstrate the new capability by performing the complete set of noise predictions (for the advanced configurations selected in task 6) necessary to provide inputs to AEDT.

Research Approach

The notional rotorcraft, along with the Bell 430 (time permitting) will be analyzed in the rotorcraft noise prediction system for all the various operating conditions. The data identified in task 5 will be produced in the appropriate format. This data will be evaluated and analyzed with tools outside of AEDT to provide detailed information about the noise of the vehicles and to provide analysis of the data delivered at the end of this task.

Milestone(s)

Predict the noise from the advanced technology configurations, prepare the data for AEDT processing, and document the data and analysis. This milestone is not schedule to be completed until the 18th month of the project.

Major Accomplishments

Work on this task has not started yet.

Publications

None

Outreach Efforts

None

Awards

None

Student Involvement

Willca Villafana, M.S. student at PSU – primarily responsible for acoustic work in Objective 2, i.e., preparing the noise prediction system to output the necessary data for input to AEDT. Expected graduation August 2016.

Umberto Saetti, M.S. student at PSU – primarily responsible for flight simulation calculations and development and debugging of the coupling between the flight simulation code and the CHARM rotor module. Expected graduation August 2016.

Plans for Next Period

This task will be completed during the next year.